



## *Professional Candle Equipment*

[www.WaxMelters.com](http://www.WaxMelters.com)  
888-WAXMELTERS  
PH (631) 938-1306

### **Pour X-Press Troubleshooting Guide**



Please review the applicable page(s) for your current challenge. This troubleshooting guide, along with your Instructions, addresses proper operation of the equipment and most of the solutions when a problem may arise.

If necessary, complete the applicable Advanced Troubleshooting Section in as much detail as possible and include a brief description of the problem and any steps that you have taken which have helped. Taking the time to answer these questions as completely as possible will expedite a resolution and prevent delays. Thank you.

## **MELTING TANK TROUBLESHOOTING**

### **Melting Tank Does Not Turn On (Red Power Button is off):**

- Make sure the outlet works.
- Make sure the fuse has not been tripped – to reset fuse, flick the trip mechanism.
- Be sure button(s), fuse(s) and controller are free from materials, wax, dripping product, debris, etc. – accumulation of materials on these components will result in shorter life-span and can lead to blown/tripped fuses, button lights to go out or controller failure.

### **Melter Blowing/Tripping Fuses:**

- Make sure no substances are leaking from the ball valve back into the Melter, which can happen if the Ball Valve is loose, there is no Teflon on the valve and/or the black gasket seal has been removed.
- Make sure no materials have dripped down the tank and onto the fuse, materials on or inside of the fuse can cause fuse to trip.
- Make sure your outlet is properly grounded and not overloaded; your melting tank should be the only appliance on the circuit.
- (2018 Models – Re-settable Fuses) Be sure fuse has not tripped (showing white front), If so-reset it.
- (Ceramic Fuse – Pre-2018) Be sure fuse cap is tight, and properly inserted, be sure fuse has not blown – also be sure nothing has dripped on/inside fuse holder.  
Ceramic fuses can be found at most local hardware stores such as Home Depot etc., in the microwave section, normally if you bring the blown fuse in with you, a store associate will be able to replace it for you.

### **Unit Heats Slowly or Unevenly or Does Not Heat At All - JOHNSON CONTROL:**

- If this occurs the first few times or after a period of inactivity, there may be a Low MEGOHM Condition (heaters may absorb moisture from the environment) which prevents heater from operating at maximum efficiency until unit is used several times and moisture evaporated out.
- Make sure the GREEN light on the control comes on. If not, then the temperature needs to be set.
- Make sure the unit is not on an extension cord, power strip, or on a line with other appliances, etc.
- Make sure to set the unit to the melting and/or mixing point (whichever is higher) recommended by the manufacturer of your materials.
- If you are melting different kinds of materials and/or materials with different melting points, densities or other properties, make sure melt and mix the higher melt points first and to keep mixing so the denser materials do not sink to the bottom
- Make sure you keep the lid on while heating to reduce heat loss and more uniform heating.
- Make sure to double check the Advanced Temperature Control Settings.
- If the unit is dirty and/or has burned materials in it, try cleaning and scrubbing it (with scouring pad if needed) as you would a stainless steel pot since this will interfere with the sensors.
- If your room is cold or you are using the unit near an open door/window, a fan, humidifier, dehumidifier, air conditioner, etc, the unit may heat slower or take more time. You may have to raise the temperature of the unit to compensate for heat loss.

#### Unit Heats Slowly or Unevenly or Does Not Heat At All- TC4 CONTROL:

- If this occurs the first few times or after a period of inactivity, there may be a Low MEGOHM Condition (heaters may absorb moisture from the environment) which prevents heater from operating at maximum efficiency until unit is used several times and moisture evaporated out.
- Make sure the green “OUT” light on the control comes on. If not, then the temperature needs to be set.
- Make sure the unit is not on an extension cord, power strip, or on a line with other appliances, etc.
- Make sure you keep the lid on while heating to reduce heat loss and more uniform heating.
- Make sure the unit is properly calibrated as instructed on PAGE 4.
- If your room is cold or you are using the unit near an open door/window, a fan, humidifier, dehumidifier, air conditioner, etc, the unit may heat slower or take more time. You may have to raise the temperature of the unit to compensate for heat loss.

#### Melter Overheating or Heating Too High- JOHNSON CONTROL

- Be sure your “OFF” and “ON” settings are correctly set – “OFF” setting must always be set higher than “ON” setting. Try separating your settings by 2 degrees (ex. OFF= 175, ON = 173).
- If you would like to change the temperature setting, you must always change both “OFF” and “ON” settings.
- Try lowering the temperature setting since depending on your location, some calibration may be required. For example, the electric may be over 120v/240v, higher altitudes have lower boiling points, humidity in a room can influence temperature and so on.
- Try removing the lid and mixing your materials to better distribute the heat.
- If the unit is dirty and/or has burned materials in it, try cleaning and scrubbing it (with scouring pad if needed) as you would a stainless steel pot since this will interfere with the sensors.
- If you are melting different kinds of materials and/or materials with different melting points, densities or other properties, make sure melt and mix the higher melt points first and to keep mixing so the dense materials do not sink to the bottom.
- Make sure you are using at least enough material to fill 1/3 of the tank.
- Try adjusting your Digital Temperature Controller settings, especially the low range before heating re-initiates.

#### Melter Overheating or Heating Too High- TC4 CONTROL

- Check your controller settings, you can find the full controller settings on page 8. It is possible some setting(s) were reset or accidentally changed. Follow the guide and be sure all relevant settings match the guide. Not every setting in the guide will appear in your controller.
- Try lowering the temperature setting since depending on your location, some calibration may be required. For example, the electric may be over 120v/240v, higher altitudes have lower boiling points, humidity in a room can influence temperature and so on.
- Try removing the lid and mixing your materials to better disburse the heat.
- Make sure the unit is properly calibrated as instructed on PAGE 4.
- Make sure you are using at least enough material to fill the chambers 1/3 high.

#### Melter Leaks

- Your Melting Tank should not leak. Before leaving our facility, it is welded and then filled with water to make sure there are no leaks since leaks would damage the electrical equipment. Next, the electrical work is completed on the unit (while the outside of the unit is not yet sealed) and it is again filled with water to test it since if there are any problems, at this point, water is easy to dispose of. Next, it is tested with materials and the sensors are calibrated. Lastly, it is finally sealed. Hence, there is no way there could have been a leak before shipping the unit.
- Make sure to check that the Teflon tape on the Ball Valve is in place.
- Make sure the Ball Valve is connected tightly with a wrench.

#### Ball Valve Clogged, No Material Pouring Out When Ball Valve Open:

- Remove any extra attachments made to the ball valve, such as extra pipe, elbow, etc., this can lead to clogging, slow flow rate and even slower heat time.
- Melting tank temperature needs to be raised – the melting point of any particular product will rise if color, fragrance, etc. are added. Also, the listed melting point is normally lower than the actual temperature required to sufficiently liquefy the product for purposes of pouring.

## **FILLING SYSTEM Basic Troubleshooting**

### **Filler Does Not Turn On (Red Power Button is off):**

- Make sure the outlet works.
- Make sure the fuse (found next to power cord) has not tripped, if it has – reset fuse.

### **Filler Tripping Fuses**

- Make sure the fuse (found next to power cord) has not tripped, if it has – reset fuse.
- Be sure fuse is clear of dripping product, dust, build-up, etc.

### **Filler Leaks**

- If you notice any materials leaking from any joints or fittings, then unplug the unit immediately. Refer to the assembly instructions and carefully tighten those joints/fittings.

### **Filler Seems Completely Clogged & Will Not Pour Any Material**

- Make sure the ball valve is open, the material in the melter completely melted and that the filler has been preheated for 1 hour if empty (up to 3 hours if full of material).
- Make sure filler is set 10-15 degrees higher than the melting tank.
- If your room is cold or you are using the unit near an open door/window, a fan, humidifier, dehumidifier, air conditioner, etc..., the unit may heat slower or take more time. You may have to raise the temperature of the unit to compensate for heat loss.

### **Filler Dispenses Slowly, Unevenly And/Or Filler Drips From The Nozzle:**

- Make sure the unit is not on an extension cord or power strip.
- Make sure it is on a dedicated line without other appliances on it.
- Make sure that filler temperature setting is 10-15 degrees higher than melting tank.
- Make sure Filler (not melter) is preheated for 1 hour if empty (up to 3 hours if full)
- Make sure the green “OUT” light on the digital temperature control comes on. If not, then the temperature needs to be set.
- If the filler pours fine at the beginning but starts dripping, leaking or pouring unevenly later, then the melter temperature needs to be raised and/or the filler temperature needs to be 10 to 15 degrees higher.
- Try removing the melter’s lid or opening it a little to allow air to flow inside.
- If your room is cold or you are using the unit near an open door/window, a fan, humidifier, dehumidifier, air conditioner, etc..., the unit may heat slower or take more time. You may have to raise the temperature of the unit to compensate for heat loss.
- If using pre-melted wax: First, make sure the ball valve is closed between the melter and filling system before adding pre-melted wax.
- If using pre-melted wax either: a) melter should be set 5-10 degrees F higher than the temperature of the pre-melted wax OR b) Have your pre-melted wax at 5-10 degrees below required melt temperature, and allow melter to heat final 5-10 F before dispensing. Otherwise the melter will believe it’s already at temperature, and not heat – therefore causing the material to begin cooling down in melter.
- Using pre-melted wax in the melting tank can also introduce air into the system. If after adding pre-melted wax, pouring is slow, the trapped air will need to be released from the system. To release the air, turn the pump power button on and off 3-4 times, allowing a few seconds rest between each – this should allow some wax to backflow into the melter and release any trapped air bubbles from the system.

# FOR PX-2000:

## ADVANCED JOHNSON CONTROLLER SETTINGS

Default Settings: Please Confirm As Your Melter Will Not Operate Properly If These Are Incorrect

★ = Default Setting

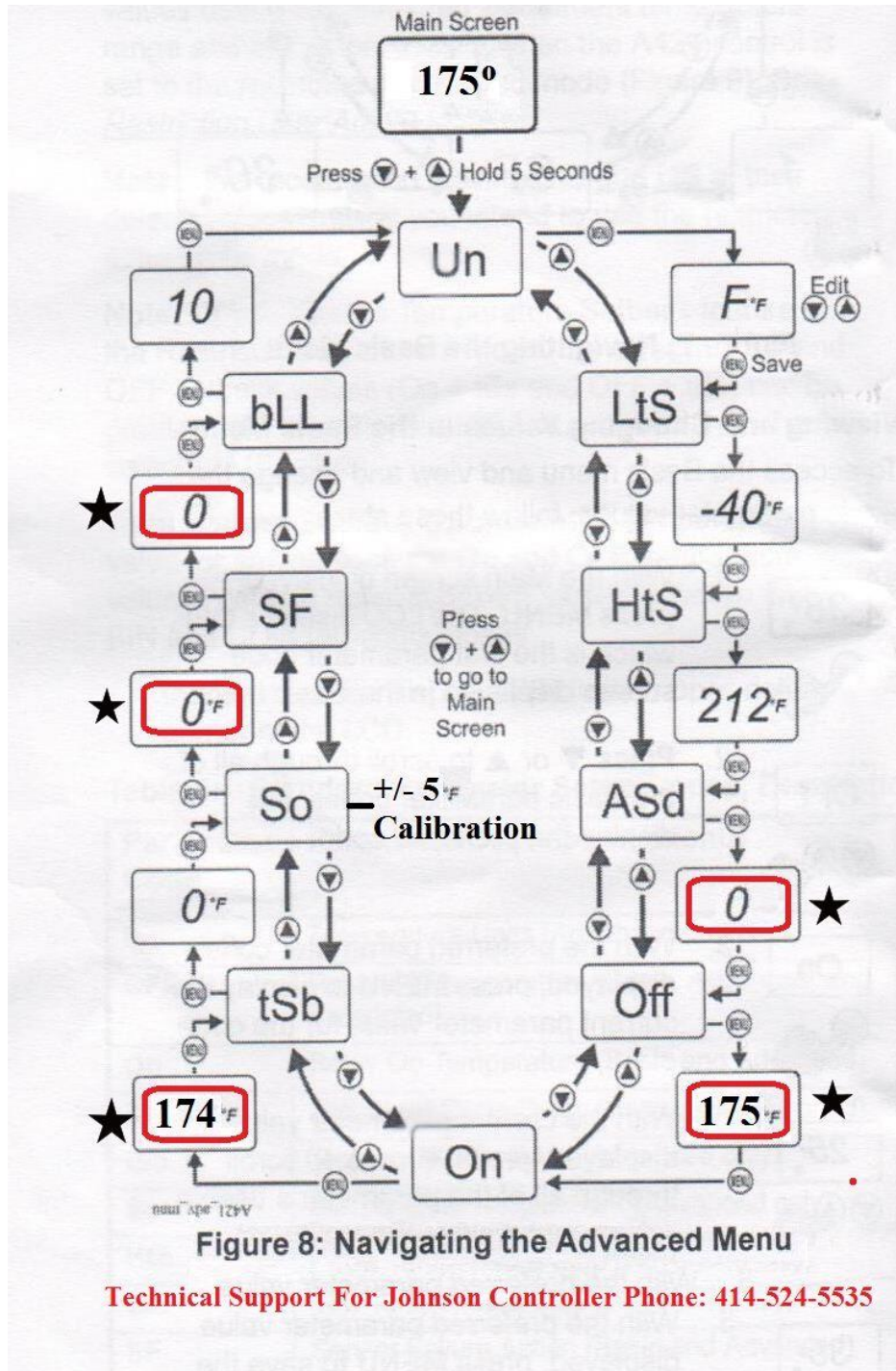

## FOR PX3000/FILLING SYSTEM:



### ADVANCED TEMPERATURE CONTROL SETTINGS (TC4S Controller)

#### For PAR1 Settings:

-Press and hold MODE until screen displays PAR1 Press MODE until it displays (setting name) Press Up or Down arrow to set each setting then press Mode to save

Setting Name - Setting value

#### PAR-1 Settings

AL-1=954

HYS=001

#### For PAR2 Settings:

-Press and hold MODE until screen displays PAR2 Press MODE until it displays (setting name) Press Up or Down arrow to set each setting then press Mode to save

#### PAR-2 Settings

Parameter	Factory default	Parameter	Factory default
In-t	JIC	t	0200
Unlt	F	AL-1	Rn1A
In-b	**	AL-2	Rn2A
nRwF	0001	RHYS	0001
L-Su	-22	LbAt	0000
H-Su	***	LbAS	008
o-Ft	HEAt	LbAb	002
C-nd	on of	dl-t	StoP
oUt	rLY	Er.nu	0000
SSr.n	Stnd	LoC	oFF

In-b \*\* = this setting should be set as follows, if you have:

X-Treme, WaxHand, Depilatory, Dip Tank Melter: 0

Filling System (2014 or Prior Hose): -20

Filling System with 2015 Hose: 0

H-Su \*\*\* = this setting should be set as follows, if you have:

Waxhands/ Depilatory wax melters: 160

Standard Melting Tanks and Filling Systems: 212

X-Treme tanks: 300

XX- Treme Tanks: 400

**FOR MELTING TANK**

**Advanced Troubleshooting: If Applicable, Please Complete & Return This Page:**

Fax to (631) 458-0911 or email it to [Support@Waxmelters.com](mailto:Support@Waxmelters.com)

Company:	Contact Name:	Contact #:
Melting Tank Size:	Approximate Purchase Date or Order #:	

**Unit Is Not Turning On And/Or Blowing/Tripping Fuses**

- 1) Did you check the power cord and try another outlet. **Y / N**
- 2) Is the fuse cap in securely with the same amp “fast blow” heated rated ceramic fuse? **Y / N**
- 3) (2018 Models & Newer) Is the Re-Settable Fuse “tripped” (showing white front?) **Y / N**  
If so, flip the re-settable fuse back to its original state (showing black front), and be sure it is free of materials, dust, debris etc. which may have dripped/gathered on it.
- 4) Does the power button come on first and after a 5-10 second delay it blows/trips the fuse? **Y / N**
- 5) Did any material potentially enter the unit through the top, a side seam or valve area? **Y / N**

**Unit Does Not Heat, Heats Slowly And/or Unevenly**

- 1) Do you feel any heat when you touch the bottom of the tank or valve? **Y / N** You may need to remove a chamber (Waxhand & Candle Carving Tanks)
- 2) Does the Green “OUT” light come on the control? **Y / N**
- 3) When the Green “OUT” light comes on, do you hear TWO “CLICK” noises? **Y / N**
- 4) Have you tried raising the temperature to compensate for heat loss and other electrical/ environmental factors (low altitude, humidity, etc...) which may require calibration? **Y / N**
- 5) Did you burn any material or notice discoloration inside the tank? **Y / N** If so, did you try scrubbing it clean (like a stainless steel pan) since the sensors will be unable to work. **Y / N**
- 6) Are you keeping the lid on and mixing your materials? **Y / N**
- 7) Did unit suddenly stop heating? **Y / N**
- 8) Did it progressively heat slower and then stop? **Y / N** Have you had any power surges, outages or roaming blackouts in your area? **Y / N**
- 9) Was the unit operated without material or very little material? **Y / N**
- 10) If you unit has chambers, is each bin must be inside the correctly numbered chamber and the # on each bin must face/be against the outside # on the chamber? **Y / N**
- 11) Controller Calibration (SO) is set to \_\_\_\_\_ & (ASD) is set to \_\_\_\_\_ (See Pg. 3 of this guide).
- 12) What is the brand and brand name of your material? \_\_\_\_\_

Melt point?\_\_\_\_\_ Melter Temperature Settings(OFF/ON)?\_\_\_\_/\_\_\_\_ How Long Does it Take?\_\_\_\_\_ If using preheated material from another tank, the preheated Temperature is \_\_\_\_\_.

**Unit Overheating And/Or Heating Too High**

- 1) Did you try lowering the temperature? **Y / N** Sometimes, depending on your location, some calibration may be required. If you are at a higher altitude, the boiling points of substances are generally lower and may require you to lower your temperature. **Y / N**
- 2) Is the unit at least 1/3 full? **Y / N**
- 3) Did you burn any material or notice discoloration inside the tank? If so, did you try scrubbing it clean (like a stainless steel pan) since the sensors will be unable to work. **Y / N**
- 4) Did you try removing the lid and mixing the materials? **Y / N**
- 5) Did you make sure your OFF and ON settings are correctly set? (OFF should always be set higher than ON, at all times. – Example: OFF=175, ON=173) **Y / N**
- 6) Try setting the OFF and ON settings closer together, such as 3-5 degrees apart (Example: OFF=175, ON=170). **Y / N**

**Please Provide A Brief Description & Any Steps That Have Helped:** \_\_\_\_\_

### **FILLING SYSTEM**

**Advanced Troubleshooting: If Applicable, Please Complete & Return This Page**

Company:	Contact Name:	Contact #:
Filler Model:	Approximate Purchase Date or	Order #:

**Filler Is Not Turning On, Blowing Fuses And/Or Leaking**

- 1) Has the breaker/fuse tripped? **Y / N**
  
- 2) If the fuse keeps tripping, first disconnect electrical connection on:
  1. Dispensing gun – Does it still trip? **Y / N**
  2. Hose – Does it still trip? **Y / N**
  
- 3) If leaking, have you made sure the fittings are tight? If so, which connection is it leaking:  
Melter to Pump                      Pump to Hose                      Hose to Head                      Pump Feet

**Filler Dispenses Slowly, Unevenly, Nozzle Drips And/Or Seems Clogged**

- 1) Does the Green “OUT” light come on the control and do you hear a “CLICK” noise? **Y / N**
  
- 2) Allow system to preheat for 1 hour. Circle if any of these connections are cool (Be careful since they should be hot):  
Melter to Pump                      Pump to Hose                      Hose to Head                      Nozzle Itself
  
- 3) Did you make sure the filler temperature is set to the HIGHEST manufacturer’s recommended Temperature (the higher of mixing/blending temperature or pouring temperature) and at least 15 degrees higher than the melter temperature? **Y / N**  
If Yes, set the temperature of Filler to 212f (It will not damage your product unless left for any extended period of time) and let it heat for 1 hour and try again. Does it pour better now? **Y / N**
  
- 4) If 2 & 3 did not help, then disconnect head from hose and aim the hose back into the tank.
  - a. If it pours quickly, did you make sure there is no wax paper, metal twine, or debris in the head? **Y / N**  
Did you try a compressor to blow out the head? **Y / N**
  - b. If it does not pour quickly, disconnect the hose. Does it pour fast from the pump (careful since it may be hot and splash) into a large pitcher or melter? **Y / N** If not, does material slowly pour out by gravity or if you tip the unit? **Y / N**  
If No, What Type of Sound Does The Pump Make?  
\_\_\_ It sounds normal    \_\_\_ It sounds stuck and is making a “buzzing” sound  
\_\_\_ There is no sound    \_\_\_ It sounds loud and like something is rattling
  
- 5) Did you apply external heat to the system? **Y / N**  
If yes, to what part? \_\_\_\_\_
  
- 6) List the material (include brand name or product#) you heating/melting and melt points?  
\_\_\_\_\_

Melter’s Temperature is Set to \_\_\_\_\_ Filler’s Temperature is Set to \_\_\_\_\_

If using preheated material from another tank, the preheated Temperature is \_\_\_\_\_

**Please Provide A Brief Description & Any Steps That Have Helped:** \_\_\_\_\_

Please answer these questions accurately to expedite a resolution and prevent delays. Thank you.

Please Fax to (631) 458-0911 or email it to [Support@Waxmelters.com](mailto:Support@Waxmelters.com)



If you require additional assistance, please take photos of the tank, its power supply, and buttons/fuses/control – forward the photos along with the above page to:

**support@waxmelters.com**

Or alternatively you can fax to:

**(631) 458-0911**



**www.WaxMelters.com**  
**888-WAXMELTERS**  
**PH (631) 938-1306**

Please answer these questions accurately to expedite a resolution and prevent delays. Thank you.

Fax to (631) 458-0911 or email it to [Support@Waxmelters.com](mailto:Support@Waxmelters.com)

**GUIDE PAGE 8**